

2.5" SATA-SSD-R2 Datasheet

CONTENTS

1. Overview 4

2. Features 5

3. Theory of operation..... 6

4. Pin Assignment and Description 8

 4.1 2.5" SATA-SSD Interface Pin Assignments (Signal Segment)..... 8

 4.2 2.5" SATA-SSD Interface Pin Assignments (Power Segment)..... 8

5. Identify Device Data 9

6. ATA Command Set 17

7. System Power Consumption 25

 7.1 DC Input Voltage 25

 7.2 Power Consumption 25

8. Device Parameters 25

9. Physical Dimension 26

Appendix: Part Number Table 27

Revision History

Rev.	Date	History
0.1	2011/3/7	1. 1 st draft

Advantech reserves the right to make changes without further notice to any products or data herein to improve reliability, function, or design. Information furnished by Advantech is believed to be accurate and reliable. However, Advantech does not assure any liability arising out of the application or use of this information, nor the application or use of any product or circuit described herein, neither does it convey any license under its patent rights nor the rights of others.

Copyright © 1983-2010 Advantech Co., Ltd. All rights reserved.

1. Overview

Advantech SQFlash 2.5" SATA-SSD (Solid State Drive) delivers all the advantages of Flash Disk technology with the Serial ATA II interface, fully compliant with standard 2.5-inch form factor. SATA Drives are replacing the older and slower (PATA) interface in embedded environments.

The SATA SSD is based on a standard 7-pin interface for data segment and 15-pin for power segment. Its capacity could provide from 8GB to 32GB. Also it can reach 95MB/s read as well as 50MB/s write performance based on SLC flash. The power consumption of Flash Disk is much lower than traditional Hard Drive. In addition, Advantech SQFlash 2.5" SATA-SSD provides hot-swapping abilities when removing, replacing or upgrading flash disks.

2. Features

■ Standard SATA interface

- Support SATA 1.5 Gbps and 3.0 Gbps interface
- SATA Revision 2.6 compliant
- Power management supported

■ Capacities

- SLC type : 8GB , 16GB , 32GB

■ Transfer Mode

- PIO Mode: 0~4
- Multiword DMA: 0~2
- Ultra DMA: 0~6

■ Performance

- SLC type
 - Sustain Read Speed up to 95 MB/s
 - Sustain Write Speed up to 50 MB/s

■ Access time : 0.7 ms

■ Error Correction Function

- Built-in ECC corrects up to 8-bit per 512-Byte

■ Temperature Ranges

- Commercial Temperature
 - 0°C to 70°C for operating
 - -55°C to 95°C for storage
- Industrial Temperature
 - -40°C to 85°C for operating
 - -55°C to 95°C for storage

■ Mechanical Specification

- Shock : 1,500G / 0.5ms
- Vibration : 20G / 7~2,000Hz

■ Humidity

- Relative Humidity : 10-95%, non-condensing

■ Data Retention

- 10 years

■ Acquired RoHS 、 CE 、 FCC Certificate

■ Acoustic : 0 dB

■ Dimension : 100 mm x 69.85 mm x 9.5 mm

3. Theory of operation

■ Overview

Below Figure shows the operation of Advantech SQFlash S25 from the system level, including the major hardware blocks. As the diagram shown, SATA II controller communicates with SATA II host interface directly. Also SATA II controller supports one flash IC.

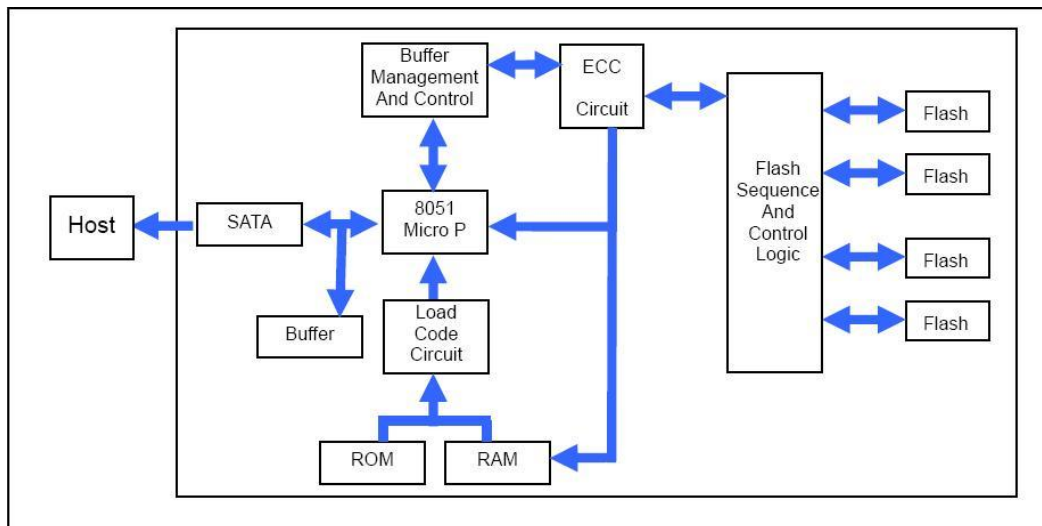

■ SATA II Controller

The SATA II controller is 3.0Gbps, and supports hot-plug. This SATA II controller support four flash IC and communicates with host interface, this SATA II controller can support the flash ICs both for 2kbyte and 4kbyte per page.

■ Error Detection and Correction

Highly sophisticated Error Correction Code algorithms are implemented. The ECC unit consists of the Parity Unit (parity-byte generation) and the Syndrome Unit (syndrome-byte computation). This unit implements an algorithm that can correct 8 bits per 512 bytes in an ECC block. Code-byte generation during write operations, as well as error detection during read operation, is implemented on the fly without any speed penalties.

■ Mean Time between Failures (MTBF)

Below table summarizes the MTBF prediction results for various Advantech SQFlash S25 configurations. The analysis is performed using a RAM Commander™ failure rate prediction.

- **Failure Rate:** The total number of failures within an item population, divided by the total number of life units expended by that population, during a particular measurement interval under stated condition.
- **Mean Time between Failures (MTBF):** A basic measure of reliability for repairable items: The mean number of life units during which all parts of the item perform within their specified limits, during a particular measurement interval under stated conditions.

Condition	MTBF (Hours)
Telcordia SR-332 GB, 25°C	> 3,000,000

■ Wear Leveling

Flash memory can be erased within a limited number of times. This number is called the erase cycle limit or write endurance limit and is defined by the flash array vendor. The erase cycle limit applies to each individual erase block in the flash device.

Advantech SQFlash S25 uses a static wear-leveling algorithm to ensure that consecutive writes of a specific sector are not written physically to the same page and block in the flash. This spreads flash media usage evenly across all pages, thereby extending flash lifetime.

■ Bad Blocks Management

Bad Blocks are blocks that contain one or more invalid bits whose reliability are not guaranteed. The Bad Blocks may be presented while the Advantech SQFlash S25 is shipped, or may develop during the life time of the SQFlash S25. The Bad Blocks will not exceed more than 6.25% of the total device volume. When the Bad Blocks is detected, it will be flagged, and not be used anymore. The SQFlash S25 implements Bad Blocks management, Bad Block replacement, Error Correct Code to avoid data error occurred. The functions will be enabled automatically to transfer data from Bad Blocks to spare blocks, and correct error bit.

4. Pin Assignment and Description

4.1 2.5" SATA-SSD Interface Pin Assignments (Signal Segment)

Pin #	Function	Description
S1	GND	2 nd mate
S2	A+	Differential signal pair A
S3	A-	
S4	GND	2 nd mate
S5	B-	Differential signal pair B
S6	B+	
S7	GND	2 nd mate

4.2 2.5" SATA-SSD Interface Pin Assignments (Power Segment)

Pin #	Function
P1	Not Used (3.3V)
P2	Not Used (3.3V)
P3	Not Used (3.3V Pre-Charge)
P4	GND
P5	GND
P6	GND
P7	5V Pre-Charge
P8	5V
P9	5V
P10	GND
P11	RESERVED
P12	GND
P13	Not Used (12V Pre-Charge)
P14	Not Used (12V)
P15	Not Used (12V)

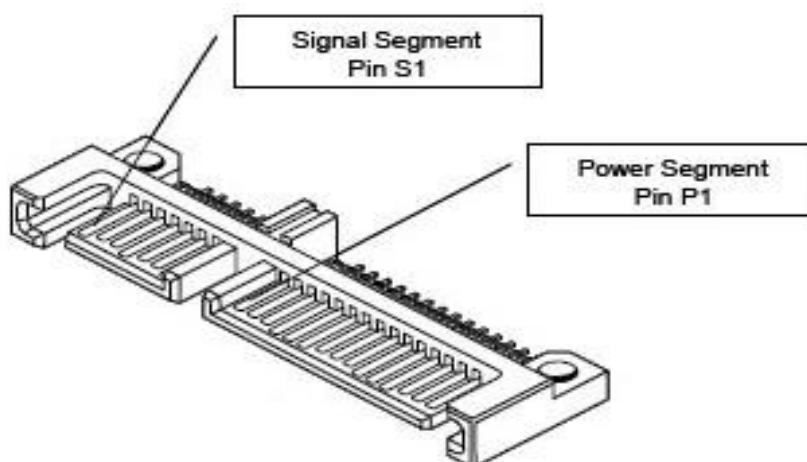

5. Identify Device Data

The Identify Device Data enables Host to receive parameter information from the device. The parameter words in the buffer have the arrangement and meanings defined in below table. All reserve bits or words are zero

Word	Description		Value
0	General configuration bit-significant information:		0040h
	15	0 = ATA device	
	14-8	Retired	
	7	1 = removable media device	
	6	Obsolete	
	5-3	Retired	
	2	Response incomplete	
	1	Retired	
	0	Reserved	
1	Obsolete		XXXXh
2	Specific configuration		C837h
3	Obsolete		00XXh
4-5	Retired		0000h
6	Obsolete		XXXXh
7-8	Reserved for assignment by the CompactFlash™ Association		0000h
9	Retired		0000h
10-19	Serial number (20 ASCII characters)		20 ASCII characters
20-21	Retired		0000h
22	Obsolete		0000h
23-26	Firmware revision (8 ASCII characters)		8 ASCII characters
27-46	Model number (40 ASCII characters)		40 ASCII characters
47	15-8 7-0	80h 00h = Reserved 01h-FFh = Maximum number of sectors that shall be transferred per interrupt on READ/WRITE MULTIPLE commands	8001h
48	Reserved		0000h
49	Capabilities		0F00h
	15-14	Reserved for the IDENTIFY PACKET DEVICE command.	
	13	1 = Standby timer values as specified in this standard are supported 0 = Standby timer values shall be managed by the device	
	12	Reserved for the IDENTIFY PACKET DEVICE command.	
	11	1 = IORDY supported 0 = IORDY may be supported	
	10	1 = IORDY may be disabled	
	9	1 = LBA supported	
	8	1 = DMA supported.	
7-0	Retired		
50	Capabilities		4001h

	15	Shell be cleared to zero	
	14:	Shall be set to one	
	13-2	Reserved	
	1	Obsolete	
	0	Shall be set to one to indicate a device specific Standby timer value minimum.	
51	Obsolete		0000h
52	Obsolete		0000h
53	15-3	Reserved	0007h
	2	1 = the fields reported in word 88 are valid 0 = the fields reported in word 88 are not valid	
	1	1 = the fields reported in words (70:64) are valid 0 = the fields reported in words (70:64) are not valid	
	0	Obsolete	
54	Number of current logical cylinders		XXXXh
55	Number of current logical heads		XXXXh
56	Number of current logical sectors per logical track		XXXXh
57-58	Current capacity in sectors		XXXXh
59	15-9	Reserved	01XXh
	8	1 = Multiple sector setting is valid	
	7-0	xxh = Current setting for number of sectors that shall be transferred per interrupt on R/W Multiple command	
60-61	Total number of user addressable sectors		XXXXXXXX Xh
62	Obsolete		0000h
63	15-11	Reserved	0X07h
	10	1 = Multiword DMA mode 2 is selected 0 = Multiword DMA mode 2 is not selected	
	9	1 = Multiword DMA mode 1 is selected 0 = Multiword DMA mode 1 is not selected	
	8	1 = Multiword DMA mode 0 is selected 0 = Multiword DMA mode 0 is not selected	
	7-3	Reserved	
	2	1 = Multiword DMA mode 2 and below are supported	
	1	1 = Multiword DMA mode 1 and below are supported	
	0	1 = Multiword DMA mode 0 is supported	
64	15-8	Reserved	0003h
	7-0	PIO modes supported	
65	Minimum Multiword DMA transfer cycle time per word		0078h
	15-0	Cycle time in nanoseconds	
66	Manufacturer's recommended Multiword DMA transfer cycle time		0078h
	15-0	Cycle time in nanoseconds	
67	Minimum PIO transfer cycle time without flow control		0078h
	15-0	Cycle time in nanoseconds	
68	Minimum PIO transfer cycle time with IORDY flow control		0078h
	15-0	Cycle time in nanoseconds	
69-70	Reserved (for future command overlap and queuing)		0000h

Specifications subject to change without notice, contact your sales representatives for the most update information.

71-74	Reserved for the IDENTIFY PACKET DEVICE command.		0000h
75	Queue depth		0000h
	15-5	Reserved	
	4-0	Maximum queue depth – 1	
76	Serial ATA capabilities		0006h
	15-13	Reserved	
	12	Supports Native Command Queuing priority information	
	11	Supports Unload while NCQ commands outstanding	
	10	Supports Phy event counters	
	9	Supports receipt of host-initiated interface power management requests	
	8	Supports Native Command Queuing	
	7-3	Reserved for future Serial ATA signaling speed grades	
	2	1 = Supports Serial ATA Gen2 signaling speed (3.0 Gbps)	
	1	1 = Supports Serial ATA Gen1 signaling speed (1.5 Gbps)	
	0	Shall be cleared to zero	
77	Reserved		0000h
78	Serial ATA features supported		0048h
	15-7	Reserved	
	6	1 = Supports software settings preservation	
	5	Reserved	
	4	1 = Supports in-order data delivery	
	3	1 = Device supports initiating interface power management	
	2	1 = Supports DMA Setup Auto-Activate optimization	
	1	1 = Supports non-zero buffer offsets in DMA Setup FIS	
0	Shall be cleared to zero		
79	Serial ATA features enabled		0040h
	15-7	Reserved	
	6	1 = Software settings preservation enabled	
	5	Reserved	
	4	1 = In-order data delivery enabled	
	3	1 = Device initiating interface power management enabled	
	2	1 = DMA Setup Auto-Activate optimization enabled	
	1	1 = Non-zero buffer offsets in DMA Setup FIS enabled	
0	Shall be cleared to zero		
80	Major version number 0000h or FFFFh = device does not report version		00FCh
	15	Reserved	
	14	Reserved for ATA/ATAPI-14	
	13	Reserved for ATA/ATAPI-13	
	12	Reserved for ATA/ATAPI-12	
	11	Reserved for ATA/ATAPI-11	
	10	Reserved for ATA/ATAPI-10	
	9	Reserved for ATA/ATAPI-9	
8	Reserved for ATA/ATAPI-8		

Specifications subject to change without notice, contact your sales representatives for the most update information.

	7	1 = supports ATA/ATAPI-7	
	6	1 = supports ATA/ATAPI-6	
	5	1 = supports ATA/ATAPI-5	
	4	1 = supports ATA/ATAPI-4	
	3	Obsolete	
	2	Obsolete	
	1	Obsolete	
	0	Reserved	
81	Minor version number 0000h or FFFFh = device does not report version		0021h
82	Command set supported.		706Bh
	15	Obsolete	
	14	1 = NOP command supported	
	13	1 = READ BUFFER command supported	
	12	1 = WRITE BUFFER command supported	
	11	Obsolete	
	10	1 = Host Protected Area feature set supported	
	9	1 = DEVICE RESET command supported	
	8	1 = SERVICE interrupt supported	
	7	1 = release interrupt supported	
	6	1 = look-ahead supported	
	5	1 = write cache supported	
	4	Shall be cleared to zero to indicate that the PACKET Command feature set is not supported.	
	3	1 = mandatory Power Management feature set supported	
	2	1 = Removable Media feature set supported	
1	1 = Security Mode feature set supported		
0	1 = SMART feature set supported		
83	Command sets supported.		7401h
	15	Shall be cleared to zero	
	14	Shall be set to one	
	13	1 = FLUSH CACHE EXT command supported	
	12	1 = mandatory FLUSH CACHE command supported	
	11	1 = Device Configuration Overlay feature set supported	
	10	1 = 48-bit Address feature set supported	
	9	1 = Automatic Acoustic Management feature set supported	
	8	1 = SET MAX security extension supported	
	7	See Address Offset Reserved Area Boot, INCITS TR27:2001	
	6	1 = SET FEATURES subcommand required to spinup after power-up	
	5	1 = Power-Up In Standby feature set supported	
	4	1 = Removable Media Status Notification feature set supported	
	3	1 = Advanced Power Management feature set supported	
	2	1 = CFA feature set supported	
1	1 = READ/WRITE DMA QUEUED supported		
0	1 = DOWNLOAD MICROCODE command supported		
84	Command set/feature supported extension		4040h
	15	Shall be cleared to zero	

Specifications subject to change without notice, contact your sales representatives for the most update information.

	14	Shall be set to one		
	13	1 = IDLE IMMEDIATE with UNLOAD FEATURE supported		
	12	Reserved for technical report		
	11	Reserved for technical report		
	10	1 = URG bit supported for WRITE STREAM DMA EXT and WRITE STREAM EXT		
	9	1 = URG bit supported for READ STREAM DMA EXT and READ STREAM EXT		
	8	1 = 64-bit World wide name supported		
	7	1 = WRITE DMA QUEUED FUA EXT command supported		
	6	1 = WRITE DMA FUA EXT and WRITE MULTIPLE FUA EXT commands supported		
	5	1 = General Purpose Logging feature set supported		
	4	1 = Streaming feature set supported		
	3	1 = Media Card Pass Through Command feature set supported		
	2	1 = Media serial number supported		
	1	1 = SMART self-test supported		
	0	1 = SMART error logging supported		
85	Command and feature sets supported or enabled			
	15	Obsolete		0
	14	1 = NOP command enabled		1
	13	1 = READ BUFFER command enabled		1
	12	1 = WRITE BUFFER command enabled		1
	11	Obsolete		0
	10	1 = Host Protected Area feature set enabled		0
	9	1 = DEVICE RESET command enabled		0
	8	1 = SERVICE interrupt enabled		0
	7	1 = release interrupt enabled		0
	6	1 = look-ahead enabled		X
	5	1 = Write Cache enabled		X
	4	Shall be cleared to zero to indicate that the PACKET Command feature set is not supported.		0
	3	1 = Power Management feature set enabled		1
	2	1 = Removable Media feature set enabled		0
1	1 = Security Mode feature set enabled	X		
0	1 = SMART feature set enabled	X		
86	Command set/feature enabled		3401h	
	15-14	0 = Reserved		
	13	1 = FLUSH CACHE EXT command supported		
	12	1 = FLUSH CACHE command supported		
	11	1 = Device Configuration Overlay supported		
	10	1 = 48-bit Address features set supported		
	9	1 = Automatic Acoustic Management feature set enabled		

Specifications subject to change without notice, contact your sales representatives for the most update information.

	8	1 = SET MAX security extension enabled by SET MAX SET PASSWORD	
	7	See Address Offset Reserved Area Boot, INCITS TR27:2001	
	6	1 = SET FEATURES subcommand required to spin-up after power-up	
	5	1 = Power-Up In Standby feature set enabled	
	4	1 = Removable Media Status Notification feature set enabled	
	3	1 = Advanced Power Management feature set enabled	
	2	1 = CFA feature set enabled	
	1	1 = READ/WRITE DMA QUEUED command supported	
	0	1 = DOWNLOAD MICROCODE command supported	
87	Command and feature sets supported or enabled		4040h
	15	Shall be cleared to zero	
	14	Shall be set to one	
	13	1 = IDLE IMMEDIATE with UNLOAD FEATURE supported	
	12	Reserved for technical report-	
	11	Reserved for technical report-	
	10	1 = URG bit supported for WRITE STREAM DMA EXT and WRITE STREAM EXT	
	9	1 = URG bit supported for READ STREAM DMA EXT and READ STREAM EXT	
	8	1 = 64 bit World wide name supported	
	7	1 = WRITE DMA QUEUED FUA EXT command supported	
	6	1 = WRITE DMA FUA EXT and WRITE MULTIPLE FUA EXT commands supported	
	5	1 = General Purpose Logging feature set supported	
	4	1 = Valid CONFIGURE STREAM command has been executed	
	3	1 = Media Card Pass Through Command feature set enabled	
	2	1 = Media serial number is valid	
	1	1 = SMART self-test supported	
0	1 = SMART error logging supported		
88	15	Reserved	XX7Fh
	14	1 = Ultra DMA mode 6 is selected 0 = Ultra DMA mode 6 is not selected	
	13	1 = Ultra DMA mode 5 is selected 0 = Ultra DMA mode 5 is not selected	
	12	1 = Ultra DMA mode 4 is selected 0 = Ultra DMA mode 4 is not selected	
	11	1 = Ultra DMA mode 3 is selected 0 = Ultra DMA mode 3 is not selected	
	10	1 = Ultra DMA mode 2 is selected 0 = Ultra DMA mode 2 is not selected	
	9	1 = Ultra DMA mode 1 is selected 0 = Ultra DMA mode 1 is not selected	
	8	1 = Ultra DMA mode 0 is selected 0 = Ultra DMA mode 0 is not selected	
7	Reserved		

	6	1 = Ultra DMA mode 6 and below are supported	
	5	1 = Ultra DMA mode 5 and below are supported	
	4	1 = Ultra DMA mode 4 and below are supported	
	3	1 = Ultra DMA mode 3 and below are supported	
	2	1 = Ultra DMA mode 2 and below are supported	
	1	1 = Ultra DMA mode 1 and below are supported	
	0	1 = Ultra DMA mode 0 is supported	
89	Time required for security erase unit completion		0000h
90	Time required for Enhanced security erase completion		0000h
91	Current advanced power management value		0000h
92	Master Password Revision Code		0000h
93	COMRESET result. The contents of this word shall be cleared to zero.		0000h
94	15-8	Vendor's recommended acoustic management value.	0000h
	7-0	Current automatic acoustic management value.	
95	Stream Minimum Request Size		0000h
96	Streaming Transfer Time – DMA		0000h
97	Streaming Access Latency – DMA and PIO		0000h
98-99	Streaming Performance Granularity		0000h
100-103	Maximum user LBA for 48-bit Address feature set.		XXXXh
104	Streaming Transfer Time – PIO		0000h
105	Reserved		0000h
106	Physical sector size / Logical Sector Size		4000h
	15	Shall be cleared to zero	
	14	Shall be set to one	
	13	1 = Device has multiple logical sectors per physical sector.	
	12	1= Device Logical Sector Longer than 256 Words	
	11-4	Reserved	
3-0	2x logical sectors per physical sector		
107	Inter-seek delay for ISO-7779 acoustic testing in microseconds		0000h
108	15-12	NAA (3:0)	0000h
	11-0	IEEE OUI (23:12)	
109	15-4	IEEE OUI (11:0)	0000h
	3-0	Unique ID (35:32)	
110	15-0	Unique ID (31:16)	0000h
111	15-0	Unique ID (15:0)	0000h
112-115	Reserved for world wide name extension to 128 bits		0000h
116	Reserved for technical report-		0000h
117-118	Words per Logical Sector		0000h
119-120	Reserved		0000h
121-126	Reserved		0000h
127	Removable Media Status Notification feature set support		0000h
	15-2	Reserved	
	1-0	00 = Removable Media Status Notification feature set not supported 01 = Removable Media Status Notification feature supported 10 = Reserved 11 = Reserved	

Specifications subject to change without notice, contact your sales representatives for the most update information.

128	Security Status		0 X 0 0 0 X X X 1
	15-9	Reserved	
	8	Security level 0 = high, 1 = Maximum	
	7-6	Reserved	
	5	1= Enhanced security erase supported	
	4	1= Security count expired	
	3	1 = Security frozen	
	2	1 = Security locked	
	1	1 = Security enabled	
0	1 = Security supported		
129-159	Vendor specific		XXXXh
160	CFA power mode 1		0000h
	15	Word 160 supported	
	14	Reserved	
	13	CFA power mode 1 is required for one or more commands implemented by the device	
	12	CFA power mode 1 disabled	
11-0	Maximum current in ma		
161-175	Reserved for assignment by the CompactFlash™ Association		0000h
176-205	Current media serial number		0000h
206-254	Reserved		0000h
255	Integrity word		XXXXh
	15-8	Checksum	
	7-0	Signature	

6. ATA Command Set

[Command Set List]

Class	Command	Code	FR	SC	SN	CY	DH	LBA
1	Check Power Mode	98H or E5H	-	-	-	-	D	-
1	Execute Device Diagnostic	90H	-	-	-	-	D	-
1	Erase Sector(s)	C0H	-	Y	Y	Y	Y	Y
2	Format Track	50H	-	Y	-	Y	Y	Y
1	Identify Device	ECH	-	-	-	-	D	-
1	NOP	00H	-	-	-	-	D	-
1	Read Buffer	E4H	-	-	-	-	D	-
1	Read Long Sector	22H or 23H	-	-	Y	Y	Y	Y
1	Read Verify Sector(s)	40H or 41H	-	Y	Y	Y	Y	Y
1	Recalibrate	1XH	-	-	-	-	D	-
1	Seek	7XH	-	-	Y	Y	Y	Y
1	Set Multiple Mode	C6H	-	Y	-	-	D	-
1	Set Sleep Mode	99H or E6H	-	-	-	-	D	-
1	Standby	96H or E2H	-	-	-	-	D	-
1	Standby Immediate	94H or E0H	-	-	-	-	D	-
2	Write Buffer	E8H	-	-	-	-	D	-

Note: FR: Feature Register
 SC: Sector Count Register
 SN: Sector Number Register
 CY: Cylinder Registers
 DH: Card/Device/Head Register
 LBA: LBA Block Address Mode Supported

[Command Set Descriptions]

1. CHECK POWER MODE (code: 98h or E5h);

Register	7	6	5	4	3	2	1	0
Command(7)	98h or E5h							
C/D/H(6)	X			Drive	X			
Cylinder High(5)	X							
Cylinder Low(4)	X							
Sector Number(3)	X							
Sector Count(2)	X							
Feature(1)	X							

This command checks the power mode. If the CompactFlash Storage is in, going to, or recovering from the sleep mode, the S25 sets BSY, sets the Sector Count Register to 00h, clears BSY and generates an interrupt. If the S25 is in idle mode, the S25 sets BSY, sets the Sector Count Register to FFh, clears BSY and generates an interrupt.

2. Execute Device Diagnostic (code: 90h);

Register	7	6	5	4	3	2	1	0
Command(7)	90h							
C/D/H(6)	X			Drive	X			
Cylinder High(5)	X							
Cylinder Low(4)	X							
Sector Number(3)	X							
Sector Count(2)	X							
Feature(1)	X							

This command performs the internal diagnostic tests implemented by the S25. When the diagnostic command is issued in the True IDE Mode, the Drive bit is ignored and the diagnostic command is executed by both the Master and the Slave with the Master responding with status for both devices. Diagnostic Codes are returned in the Error Register at the end of the command.

Code	Error Type
01h	No Error Detected
02h	Formatter Device Error
03h	Sector Buffer Error
04h	ECC Circuitry Error
05h	Controller Microprocessor Error
8Xh	Slave Error in True IDE Mode

3. Erase Sector(s) (code: C0h);

Register	7	6	5	4	3	2	1	0
Command(7)	C0h							
C/D/H(6)	1	LBA	1	Drive	Head (LBA 27-24)			
Cylinder High(5)	Cylinder High (LBA 23-16)							
Cylinder Low(4)	Cylinder Low (LBA 15-8)							
Sector Number(3)	Sector Number (LBA 7-0)							
Sector Count(2)	Sector Count							
Feature(1)	X							

This command is used to pre-erase and condition data sectors in advance of a Write without Erase or Write Multiple without Erase command. There is no data transfer associated with this command but a Write Fault error status can occur.

4. Format Track (code: 50h);

Register	7	6	5	4	3	2	1	0
Command(7)	50h							
C/D/H(6)	1	LBA	1	Drive	Head (LBA 27-24)			
Cylinder High(5)	Cylinder High (LBA 23-16)							
Cylinder Low(4)	Cylinder Low (LBA 15-8)							
Sector Number(3)	X (LBA 7-0)							
Sector Count(2)	Count(LBA mode only)							
Feature(1)	X							

This command writes the desired head and cylinder of the selected drive with a vendor unique data pattern (typically FFh or 00h). To remain host backward compatible, the S25 expects a sector buffer of data from the host to follow the command with the same protocol as the Write Sector(s) command although the information in the buffer is not used by the S25. If LBA=1 then the number of sectors to format is taken from the Sec Cnt register (0=256).

5. Identify Device (code: ECh);

Register	7	6	5	4	3	2	1	0
Command(7)	ECh							
C/D/H(6)	X	X	X	Drive	X			
Cylinder High(5)	X							
Cylinder Low(4)	X							
Sector Number(3)	X							
Sector Count(2)	X							
Feature(1)	X							

The Identify Device command enables the host to receive parameter information from the S25. This command has the same protocol as the Read Sector(s) command. All reserved bits or words are zero. Hosts should not depend in Obsolete words in Identify Device containing 0.

6. NOP (code: 00h);

Register	7	6	5	4	3	2	1	0
Command(7)	00h							
C/D/H(6)	X				Drive	X		
Cylinder High(5)	X							
Cylinder Low(4)	X							
Sector Number(3)	X							
Sector Count(2)	X							
Feature(1)	X							

This command always fails with the S25 returning command aborted.

7. Read Buffer (code: E4h);

Register	7	6	5	4	3	2	1	0
Command(7)	E4h							
C/D/H(6)	X				Drive	X		
Cylinder High(5)	X							
Cylinder Low(4)	X							
Sector Number(3)	X							
Sector Count(2)	X							
Feature(1)	X							

The Read Buffer command enables the host to read the current contents of the S25 sector buffer. This command has the same protocol as the Read Sector(s) command.

8. Read Long Sector (code: 22h or 23h);

Register	7	6	5	4	3	2	1	0
Command(7)	22h or 23h							
C/D/H(6)	1	LBA	1	Drive	Head (LBA 27-24)			
Cylinder High(5)	Cylinder High (LBA 23-16)							
Cylinder Low(4)	Cylinder Low (LBA 15-8)							
Sector Number(3)	Sector Number (LBA 7-0)							
Sector Count(2)	X							
Feature(1)	X							

The Read Long command performs similarly to the Read Sector(s) command except that it returns 516 bytes of data instead of 512 bytes. During a Read Long command, the S25 does not check the ECC bytes to determine if there consists of 512 bytes of data transferred in word mode followed by 4 bytes of ECC data transferred in byte mode. This command has the same protocol as the Read Sector(s) command. Use of this command is not recommended.

9. Read Sector(s) (code: 20h or 21h);

Register	7	6	5	4	3	2	1	0
Command(7)	20h or 21h							
C/D/H(6)	1	LBA	1	Drive	Head (LBA 27-24)			
Cylinder High(5)	Cylinder High (LBA 23-16)							
Cylinder Low(4)	Cylinder Low (LBA 15-8)							
Sector Number(3)	Sector Number (LBA 7-0)							
Sector Count(2)	Sector Count							
Feature(1)	X							

This command reads from 1 to 256 sectors as specified in the Sector Count Register. A sector count of 0 requests 256 sectors. The transfer begins at the sector specified in the Sector Number Register. When this command is issued and after each sector of data (except the last one) has buffer, sets DRQ, clears BSY, and generates an interrupt. The host then reads the 512 bytes of data from the buffer.

At command completion, the Command Block Registers contain the cylinder, head and sector number of the last sector read. If an error occurs, the read terminates at the sector where the error occurred. The command Block Registers contain the cylinder head, and sector number of the sector where the error occurred. The flawed data is pending in the sector buffer.

10. Read Verify Sector(s) (code: 40h or 41h);

Register	7	6	5	4	3	2	1	0
Command(7)	40h or 41h							
C/D/H(6)	1	LBA	1	Drive	Head (LBA 27-24)			
Cylinder High(5)	Cylinder High (LBA 23-16)							
Cylinder Low(4)	Cylinder Low (LBA 15-8)							
Sector Number(3)	Sector Number (LBA 7-0)							
Sector Count(2)	Sector Count							
Feature(1)	X							

This command is identical to the Read Sectors command, except that DRQ is never set and no data is transferred to the host. When the command is accepted, the S25 sets BSY. When the requested sectors have been verified, the S25 clears BSY and generates an interrupt. Upon command completion, the Command Block Registers contain the cylinder, head, and sector number of the last sector verified. If an error occurs, the Read Verify Command terminates at the sector where the error occurs. The Command Block Registers contain the cylinder, head and sector number of the sector where the error occurred. The Sector Count Register contains the number of sectors not yet verified.

11. Recalibrate (code: 1Xh);

Register	7	6	5	4	3	2	1	0
----------	---	---	---	---	---	---	---	---

Command(7)	1Xh				
C/D/H(6)	1	LBA	1	Drive	X
Cylinder High(5)	X				
Cylinder Low(4)	X				
Sector Number(3)	X				
Sector Count(2)	X				
Feature(1)	X				

This command is effectively a NOP command to the S25 and is provided for compatibility.

12. Seek (code: 7Xh);

Register	7	6	5	4	3	2	1	0
Command(7)	7Xh							
C/D/H(6)	1	LBA	1	Drive	Head (LBA 27-24)			
Cylinder High(5)	Cylinder High (LBA 23-16)							
Cylinder Low(4)	Cylinder Low (LBA 15-8)							
Sector Number(3)	X (LBA 7-0)							
Sector Count(2)	X							
Feature(1)	X							

This command is effectively a NOP command to the S25 although it does perform a range check of cylinder and head or LBA address and returns an error if the address is out of range.

13. Set Multiple Mode (code: C6h);

Register	7	6	5	4	3	2	1	0
Command(7)	C6h							
C/D/H(6)	X				Drive	X		
Cylinder High(5)	X							
Cylinder Low(4)	X							
Sector Number(3)	X							
Sector Count(2)	Sector Count							
Feature(1)	X							

This command enables the S25 to perform Read and Write Multiple operations and establishes the block count for these commands. The Sector Count Register is loaded with the number of sectors per block. Upon receipt of the command, the S25 sets BSY to 1 and checks the Sector Count Register. If the Sector Count Register contains a valid value and the block count is supported, the value is loaded and execution is enabled for all subsequent Read Multiple and Write Multiple commands. If the Sector Count Register contains 0 when the command is issued, Read and Write Multiple commands are disabled. At power on, or after a hardware or (unless disabled by a Set Feature command) software reset, the default mode is Read and Write multiple disabled.

14. Set Sleep Mode (code: 99h or E6h);

Register	7	6	5	4	3	2	1	0
Command(7)	99h or E6h							
C/D/H(6)	X				Drive	X		
Cylinder High(5)	X							
Cylinder Low(4)	X							
Sector Number(3)	X							
Sector Count(2)	X							
Feature(1)	X							

This command causes the S25 to set BSY, enter the Sleep mode, clear BSY and generate an interrupt. Recovery from sleep mode is accomplished by simply issuing another command (a reset is permitted but not required). Sleep mode is also entered when internal timers expire so the host does not need to issue this command except when it wishes to enter Sleep mode immediately. The default value for the timer is

5 milliseconds.

15. Standby (code: 96h or E2h);

Register	7	6	5	4	3	2	1	0
Command(7)	96h or E2h							
C/D/H(6)	X			Drive	X			
Cylinder High(5)	X							
Cylinder Low(4)	X							
Sector Number(3)	X							
Sector Count(2)	X							
Feature(1)	X							

This command causes the S25 to set BSY, enter the Sleep mode, clear BSY and return interrupt immediately. Recovery from sleep mode is accomplished by simply issuing another command (a reset is not required).

16. Standby Immediate (code: 94h or E0h);

Register	7	6	5	4	3	2	1	0
Command(7)	94h or E0h							
C/D/H(6)	X			Drive	X			
Cylinder High(5)	X							
Cylinder Low(4)	X							
Sector Number(3)	X							
Sector Count(2)	X							
Feature(1)	X							

This command causes the S25 to set BSY, enter the Sleep mode, clear BSY and return the interrupt immediately. Recovery from sleep mode is accomplished by simply issuing another command (a reset is not required).

17. Write Buffer (code: E8h);

Register	7	6	5	4	3	2	1	0
Command(7)	E8h							
C/D/H(6)	X			Drive	X			
Cylinder High(5)	X							
Cylinder Low(4)	X							
Sector Number(3)	X							
Sector Count(2)	X							
Feature(1)	X							

The Write Buffer command enables the host to overwrite contents of the S25 sector buffer with any data pattern desired. This command has the same protocol as the Write Sector(s) command and transfer 512 bytes.

18. Security Set Password (code: F1h);

Register	7	6	5	4	3	2	1	0
Features	Na							
Sector Count	Na							
LBA Low	Na							
LBA Mid	Na							
LBA High	Na							
Device	obs	Na	obs	Na	Na			
Command	F1h							

This command transfer 512 byte of data from the host. The revision code field shall be returned in the IDENTIFY DEVICE word 92. The valid revision codes are 0001h through FFFh. A value of 0000h or FFFFh indicates that the Master Password Revision Code is not supported.

19. Security Unlock (code: F2h);

Register	7	6	5	4	3	2	1	0
Features	Na							
Sector Count	Na							
LBA Low	Na							
LBA Mid	Na							
LBA High	Na							
Device	obs	Na	obs	Na	Na			
Command	F2h							

This command transfers 512 bytes of data from the host. If the Identifier bit is set to Master and the device is in high security level, then the password supplied shall be compared with the stored Master password. If the device is in maximum security level then the unlock shall be rejected.

If the Identifier bit is set to user then the device shall compare the supplied password with the stored User password. If the password compare fails then the device shall return command aborted to the host and decrements the unlock counter. This counter shall be initially set to five and shall decremented for each password mismatch when SECURITY UNLOCK and SECURITY ERASE UNIT commands shall be command aborted until a power-on reset or a hardware reset. SECURITY UNLOCK commands issued when the device is unlocked have no effect on the unlock counter.

20. Security Erase Prepare (code: F3h);

Register	7	6	5	4	3	2	1	0
Features	Na							
Sector Count	Na							
LBA Low	Na							
LBA Mid	Na							
LBA High	Na							
Device	obs	Na	obs	Na	Na			
Command	F3h							

The SECURITY ERASE PREPARE command shall be issued immediately before the SECURITY ERASE UNIT command to enable device erasing and unlocking. This command prevents accidental loss of data on the device.

21. Security Erase Unit (code: F4h);

Register	7	6	5	4	3	2	1	0
Features	Na							
Sector Count	Na							
LBA Low	Na							
LBA Mid	Na							
LBA High	Na							
Device	obs	Na	obs	Na	Na	Na	Na	Na
Command	F4h							

This command transfer 512 bytes of data from the host. If the password does not match the password previously saved by the device, the device shall reject the command with command aborted. The SECURITY ERASE PREPARE command shall be completed immediately prior to the SECURITY ERASE UNIT command. If the device receives a SECURITY ERASE UNIT command without an immediately prior SECURITY ERASE PREPARE command, the device shall command abort the SECURITY ERASE UNIT command. When Normal Erase mode is specified, the SECURITY ERASE

UNIT command shall write binary zeroes to all user data areas. The Enhanced Erase mode is optional. When Enhanced Erase Mode is specified, the device shall write predetermined data patterns to all user areas. In Enhanced Erase mode, all previously written user data shall be overwritten, including sectors that are no longer in use due to reallocation. This command shall disable the device Lock mode, however, the Master password shall still be stored internally within the device and may be reactivated later a new User password is set.

22. Security Freeze Lock (code: F5h);

Register	7	6	5	4	3	2	1	0
Features	Na							
Sector Count	Na							
LBA Low	Na							
LBA Mid	Na							
LBA High	Na							
Device	Obs	Na	obs	Na	Na	Na	Na	Na
Command	F5h							

The SECURITY FREEZE LOCK command shall set the device to Frozen mode. After command completion any other commands that update the device Lock mode shall be command aborted. Frozen mode shall be disabled by power-off or hardware reset. If SECURITY FREEZE LOCK shall be issued when the device in Frozen mode, the command executes and the device shall remain in Frozen mode.

23. Security Disable Password (code: F6h);

Register	7	6	5	4	3	2	1	0
Features	Na							
Sector Count	Na							
LBA Low	Na							
LBA Mid	Na							
LBA High	Na							
Device	obs	Na	obs	Na	Na	Na	Na	Na
Command	F6h							

The SECURITY DISABLE PASSWORD command transfer 512 bytes of data from the host. If the password selected by word 0 matches the password previously saved by the device, the device shall disable the Lock mode. This command shall not change the Master password. The Master password shall be reactivated when a User password if set.

7. System Power Consumption

7.1 DC Input Voltage

Parameter	Rating
Operating Voltage	5V +/- 5%

7.2 Power Consumption

Parameter	Value
Sustained Read	100 mA (max.)
Sustained Write	150 mA (max.)
IDLE	55 mA (max.)

8. Device Parameters

Capacity	Cylinders	Heads	Sectors	LBA
8GB	15,603	16	63	15,727,824
16GB	16,383	16	63	31,277,056
32GB	16,383	16	63	62,586,880

9. Physical Dimension
2.5" SATA SSD (Unit: mm)

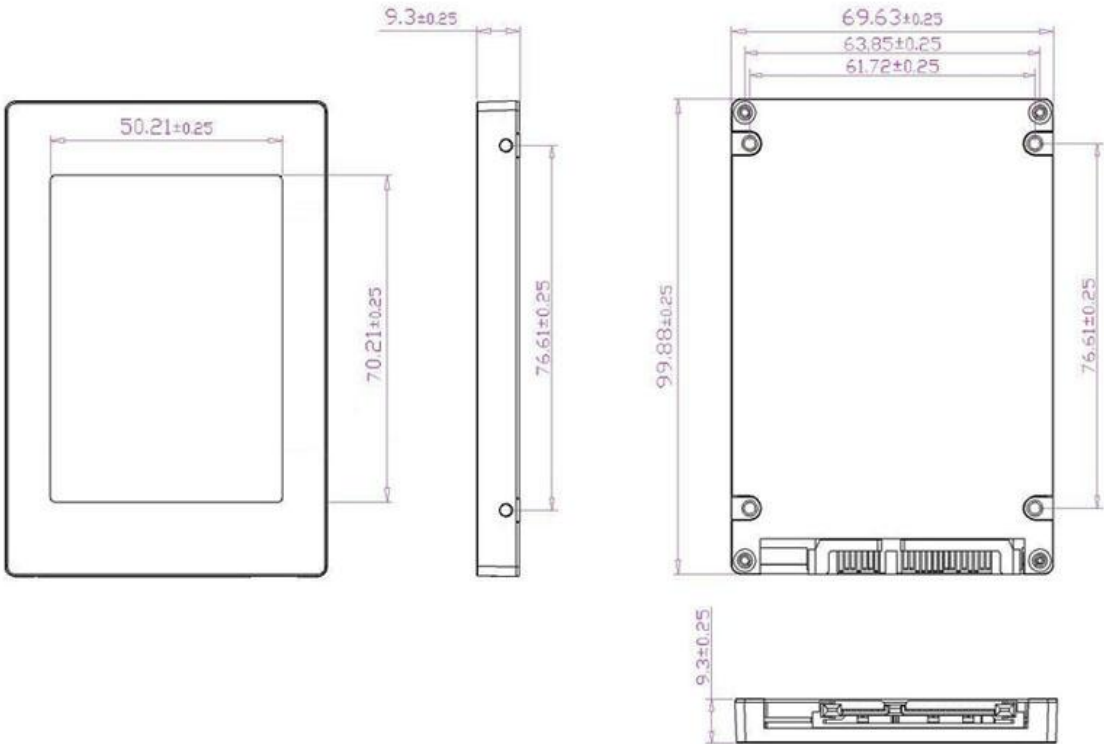

Appendix: Part Number Table

Description	PN
SQFlash S25 SLC, 4-CH, 8GB (0~70°C)	SQF-S25S4-8G-R2C
SQFlash S25 SLC, 4-CH, 16GB (0~70°C)	SQF-S25S4-16G-R2C
SQFlash S25 SLC, 4-CH, 32GB (0~70°C)	SQF-S25S4-32G-R2E
SQFlash S25 SLC, 4-CH, 8GB (-40~85°C)	SQF-S25S4-8G-R2E
SQFlash S25 SLC, 4-CH, 16GB (-40~85°C)	SQF-S25S4-16G-R2E
SQFlash S25 SLC, 4-CH, 32GB (-40~85°C)	SQF-S25S4-32G-R2E